

## Toggle clamps horizontal with flat foot and adjustable clamping spindle

Item description/product images

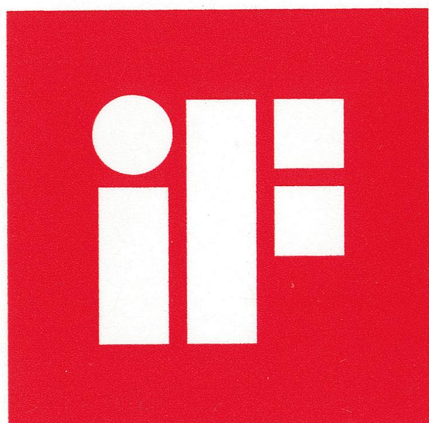

# KIPPlOCK



product  
design  
award



Angle bracket for front face  
mounting (see accessories)

### Description

**Material:**

Steel.  
Grip polyamide.

**Version:**

Nitro-carburized and black oxidized.

**Note:**

Maintenance-free high quality link bushings. Sustainable constant force during opening and closing. Optimum stability through the conical, U-profile clamping arm.

**Accessory:**

K0106  
K0098  
K0383  
K0388  
K0390  
K0391  
K0392  
K0393

# Toggle clamps horizontal with flat foot and adjustable clamping spindle

Item description/product images

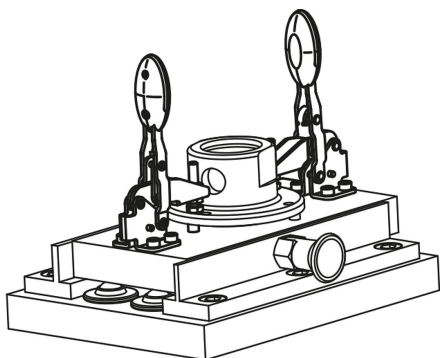

## Drawings

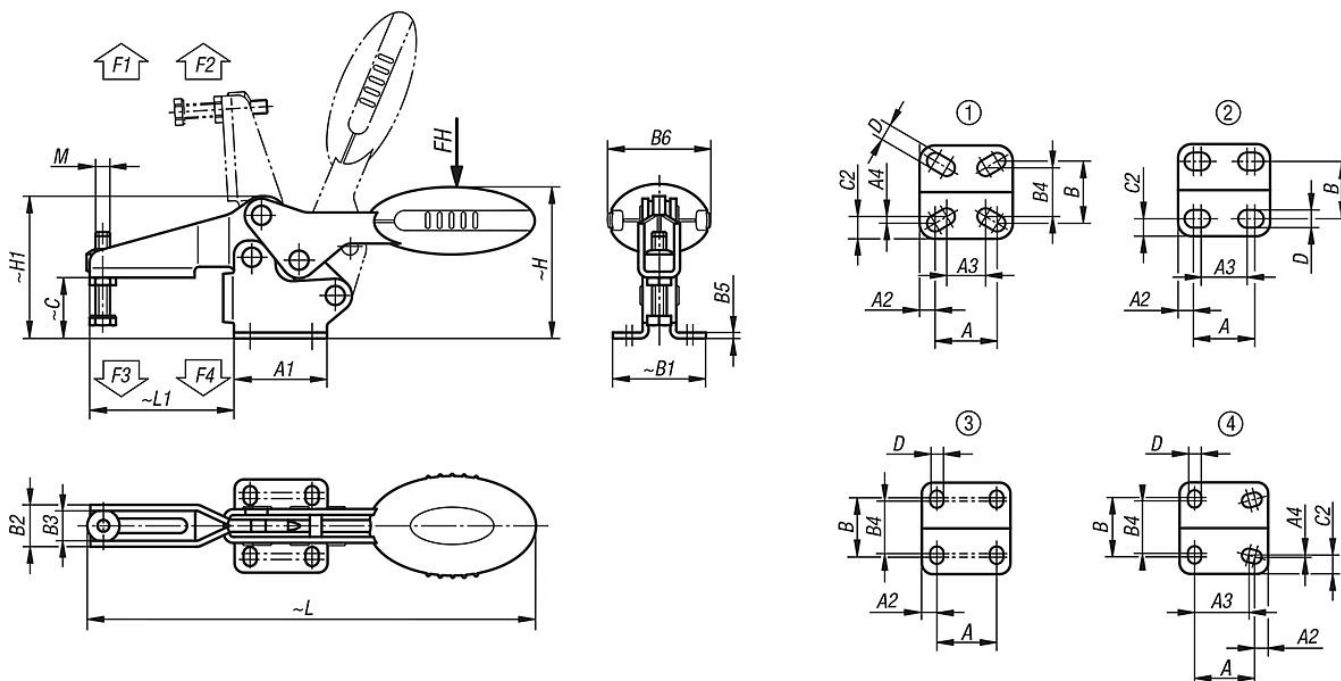

## Overview of items

### Toggle clamps horizontal with flat foot and adjustable clamping spindle

Order No.	hole arrangement	Opening angle of holding arm				Opening angle of handle				Hand force FH N	Retaining force F1 N	Retaining force F2 N	Clamping force F3 N	Clamping force F4 N	Order No. Angle bracket					
K0660.004001	1	87°				69°				80	400	500	250	300	K0098.02					
K0660.005001	2	86°				67°				100	650	900	550	620	K0098.02					
K0660.006001	3	86°				67°				160	1350	1900	720	1200	K0098.04					
K0660.008001	3	86°				67°				200	2000	2800	830	1400	K0098.04					
K0660.010001	3	90°				71°				250	2200	4500	1200	2800	K0098.06					
K0660.012001	4	88°				68°				280	2400	5500	1000	2800	K0098.06					
Order No.	M	A	A1	A2	A3	A4	B	B1	B2	B3	B4	B5	B6	C	C2	D	H	H1	L	L1
K0660.004001	M4x16	16	24	4	12,8	0,95	16	24	10,2	7,2	14,1	1,5	20	11,7	4,95	4,2	28,7	26,3	91,8	23,7
K0660.005001	M5x25	18	27	4,5	13,5	-	16,8	27,3	13,2	9,2	-	2	22,5	17,2	5,25	5,5	43,4	38,9	125,7	41,8
K0660.006001	M6x35	26	39	6,5	-	-	28	39	17,5	12,5	23	2,5	43,5	25,4	-	5,5	63,7	59,6	186,6	60,5
K0660.008001	M8x45	26	44	9	-	-	31	45	21	16	24	2,5	41,5	32,2	-	6,2	73,9	70,1	223,1	74,9
K0660.010001	M10x55	41,5	59	9	-	-	43	59	26	19	39	3,5	47	40	-	8,8	94,8	88	279,4	103,9

## Toggle clamps horizontal with flat foot and adjustable clamping spindle

### Overview of items

Order No.	M	A	A1	A2	A3	A4	B	B1	B2	B3	B4	B5	B6	C	C2	D	H	H1	L	L1
K0660.012001	M12x70	44	65	10	40	1	42	67	28	21	40	3,5	47	52,3	13,5	8,5	104,8	101,6	314,7	122