

Spring plungers with head

Item description/product images



Description

Material:

Steel or stainless steel.

Version:

Steel black oxidised.

Stainless steel bright.

Ball steel or stainless steel, hardened, bright.

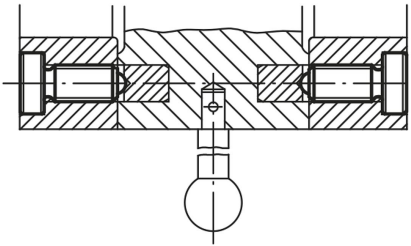

Drawings

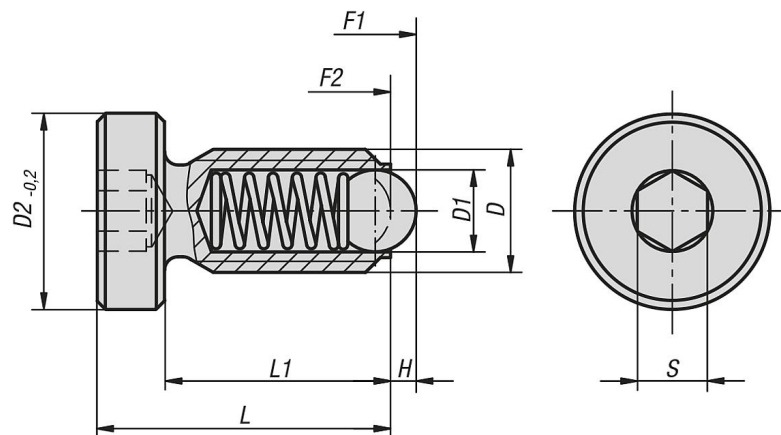

Overview of items

Spring plungers with head

Order No.	Main material	D	D1	D2	L	L1	H	S	Spring force initial pressure F1 approx. N	Spring force final pressure F2 approx. N
K0336.04	steel	M4	2,5	7	13	10	0,8	2	4	10
K0336.05	steel	M5	3	8,5	17	13	0,9	2,5	6	11
K0336.06	steel	M6	3,5	10	16	12	1	3	9	13
K0336.08	steel	M8	5	13	21	16	1,5	4	15	30
K0336.10	steel	M10	6	16	26	20	2	5	20	35
K0336.12	steel	M12	8	18	32	25	2,5	6	30	55
K0336.041	stainless steel	M4	2,5	7	13	10	0,8	2	4	10
K0336.051	stainless steel	M5	3	8,5	17	13	0,9	2,5	6	11
K0336.061	stainless steel	M6	3,5	10	16	12	1	3	9	13
K0336.081	stainless steel	M8	5	13	21	16	1,5	4	15	30
K0336.101	stainless steel	M10	6	16	26	20	2	5	20	35
K0336.121	stainless steel	M12	8	18	32	25	2,5	6	30	55

